

SULLAIR AIR TREATMENT

**Dryers: Refrigerated and Desiccant
Filtration and Mist Elimination, SP Oil/Water Separators, Drains**



SULLAIR AN INDUSTRY LEADER

LEADERSHIP

Since 1965, Sullair has been recognized worldwide as an innovator and leader in rotary screw compression and vacuum technology. Sullair designs and manufactures its own rotors and air end assemblies. The award-winning rotary screw design sets the industry standard and delivers the quality and reliability you expect from a leader.

TECHNOLOGY

Using the most modern technologies, equipment and advanced manufacturing techniques, Sullair designs, manufactures, assembles, and tests the most innovative compressed air and vacuum products in the industry. Sullair products are known around the world for their universally applicable design, outstanding craftsmanship and superior quality.

COMMITMENT TO INNOVATION

Underlying Sullair leadership is a dedication to excellence and a commitment to innovation. We are constantly exploring new ideas and seeking new ways to meet the industry's need for increasingly energy efficient compressed air and vacuum solutions.

THE IMPORTANCE OF CLEAN, DRY COMPRESSED AIR

HOW MUCH WATER IS TOO MUCH? ANY AMOUNT OF WATER IS TOO MUCH.

Water jeopardizes everything you want your compressed air system to do. It ruins product and fouls processes. Removing it is vital in order to protect both your equipment and your operations.

- Moisture in compressed air remains in a vapor state through the compression cycle, so it is not a problem until it leaves the compressor.
- At 75°F (24°C) and 75% relative humidity, a 75 hp compressor takes in 46 gallons of water vapor in 24 hours. When this air is cooled to approximately 35°F (2°C) at 100 psig, the water vapor condenses into 46 gallons of liquid.

A well-designed air treatment system has a number of critical stages, each contributing to the goal of clean, dry air. The following diagram represents a sample of a complete system from start to finish - follow along as it reappears at the bottom throughout the brochure, with individual components highlighted as they are discussed.

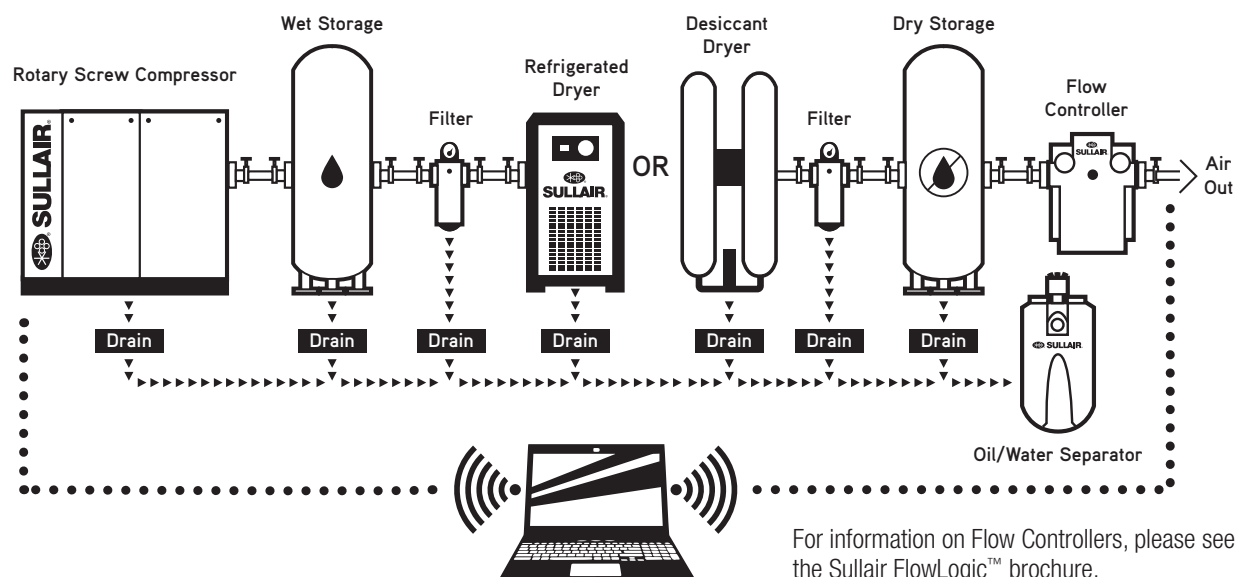

REFRIGERATED DRYERS



Refrigerated dryers remove moisture from compressed air by cooling the air — thereby reducing the ability of the air to hold moisture.

SULLAIR REFRIGERATED DRYERS ARE AVAILABLE IN THE FOLLOWING CONFIGURATIONS

- RN — Refrigerated Non-Cycling — 5 to 325 scfm
- RD — Refrigerated Digital Cycling — 400 to 6000 scfm
- RC — Refrigerated Cycling — 150 to 3000 scfm
- RH — Refrigerated High Temperature — 15 to 100 scfm

Sullair refrigerated dryers are registered with CAGI and feature:

- State of the art heat exchanger design
- Evaporator with multi-stage separator stainless steel demister
- Low power consumption with energy saving features including:
 - *3-in-1 heat exchanger*
 - *High efficiency compressors*
- Globally marketable refrigerant R-134a
- Consistent dew point performance
- Low pressure drop
- Refrigerant analyzer indicator
- Fan cycle switch
- High quality fan motors
- Oversized condenser
- Removable side panels and parts for easy serviceability

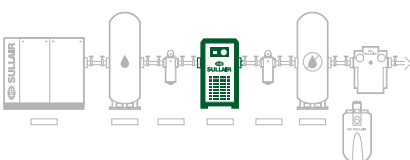

SULLAIR REFRIGERATED DRYERS



RN SERIES

REFRIGERATED NON-CYCLING DRYERS

5 – 325 SCFM

- Registered with CAGI
- 60Hz capacities from 5 to 325 scfm
- 50Hz capacities from .42 to 9.2 m³/min
- Compact footprint
- Variable flow capacity from 10% to 100%
- High inlet temperature — up to 150°F (65.5°C)
- Non-velocity sensitive demister/separator



RD SERIES

REFRIGERATED DIGITAL CYCLING DRYERS

400 – 6000 SCFM

- Registered with CAGI
- 60Hz capacities from 400 to 6000 scfm
- 50Hz capacities from 11.3 to 169.9 m³/min
- Optimum dew point levels for the highest system performance
- Digital cycling control for increased energy savings
- Energy efficient scroll compressor



RC SERIES

REFRIGERATED CYCLING DRYERS

150 – 3000 SCFM

- Registered with CAGI
- 60Hz capacities from 150 to 3000 scfm
- 50Hz capacities from 4.2 to 84.9 m³/min
- Stainless steel pump and cold storage tank
- Thermal expansion valve
- Programmable temperature controller
- Energy savings at low loads
- Intermittent compressor operation
- Simple refrigerant circuit
- Thermal mass storage medium
- Accurate dew point control



RH SERIES

HIGH TEMPERATURE DRYERS

15 – 100 SCFM

- Registered with CAGI
- 60Hz capacities from 15 to 100 scfm
- Inlet temperature up to 240°F (115.6°C)
- Independent air-cooled aftercooler
- Moisture separator
- Two independent timer drains

All Sullair Refrigerated Dryers come with a 3-year bumper-to-bumper warranty.

DESICCANT REGENERATIVE DRYERS

Desiccant dryers adsorb moisture from the compressed air as the air passes through the desiccant.



SULLAIR DESICCANT DRYERS ARE AVAILABLE IN THE FOLLOWING CONFIGURATIONS:

- DMD — Desiccant Modular Dryer — 3 to 240 scfm
- DHL — Desiccant Heatless Dryer — 80 to 5000 scfm
- DEX — Desiccant Externally Heated Dryer — 200 to 3500 scfm
- DBP — Desiccant Blower Purge Dryer — 500 to 10,000 scfm

Desiccant Dryer Features

The Sullair desiccant regenerative dryer family is ideal for outdoor compressed air piping and operations that require an extremely low dew point to -40°F (-4°F or -100°F optional). By combining the proven benefits of desiccant drying with the most advanced designs, Sullair offers a reliable system to clean and dry compressed air for the most critical applications.

Max Inlet Temperature: 150°F (66°C)
Max Inlet Pressure: 230 psig
Max Ambient Temperature: 120°F (50°C)

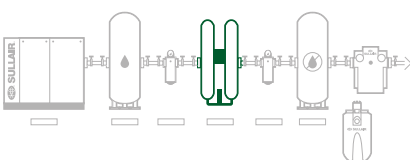

SULLAIR DESICCANT REGENERATIVE DRYERS



DESICCANT MODULAR DRYER (DMD)

STANDARD FEATURES

- Completely automatic
- Compact design
- -40°F pressure dew point
- Adjustable wall mounted
- Quick and easy connection
- Long-lasting high-quality components

OPTIONS

- Pre- and after-filter (shipped loose)
- Mounted filters with three valve bypass
- Visual Moisture Indicator
- Energy efficient Demand Cycle Control with dew point monitor
- Dew point monitor
- -4°F (-20°C) or -100°F (-73°C) pressure dew point



DHL SERIES

80 – 5000 SCFM

STANDARD FEATURES

- PLC controls with text display
- Pre- and after-filter pre-piped and mounted
- Field adjustable drying cycle time (10–15 min.)
- Pilot air filter
- Easy front access control panel
- -40°F pressure dew point
- Fully automatic self contained dryer
- Adjustable purge valves
- High quality valves
- Purge flow indicator
- ASME/CRN code welded pressure vessels
- UL/CUL electrical certified
- Separate drain and fill port
- Robust steel frame with floor stand
- Separate safety pressure relief valve for each tank
- Stainless steel inlet/outlet diffusers

OPTIONS

- Demand Cycle Controller
- NEMA 4, 4x enclosure
- High pressure up to 500 psig
- Failure to shift alarm
- Pneumatic control timer
- Optional voltage
- High dew point alarm
- Dew point monitoring system
- -4°F (-20°C) and -100°F (-73°C) pressure dew point
- 3 valve and 9 valve bypass options
- Visual moisture indicator
- Low ambient package
- Sub zero ambient package

SULLAIR DESICCANT REGENERATIVE DRYERS



DEX AND DBP SERIES

200 – 10,000 SCFM

STANDARD FEATURES

- Same high quality standard features as DHL
- Insulated heater housing and piping
- High outlet temperature shut off and alarm
- User-friendly diagnostic control display
- Safety back-up contactors
- PLC control and display (Siemens)
- Thermostatically controlled heating
- Safety heater thermostat
- Low-watt density heater
- Tower pressure gauges
- Fail safe design in case of power failure
- Color touch screen monitor
- PLC ethernet communication port

OPTIONS

- Demand Cycle Control
- Pre-piped filter and bypass packages
- Low bed temperature shut off with light and contact
- High heater remote temperature alarm
- NEMA 4, 4x enclosures
- Visual moisture indicator
- 3 valve and 9 valve bypass options
- Optional voltage
- Failure to shift alarm
- -4°F (-20°C) pressure dew point
- Purge flow meter
- Dew point monitoring system
- Low ambient package
- Microprocessor based controls/Modbus
- Sub zero ambient package
- Allen Bradley PLC with color touch screen monitor

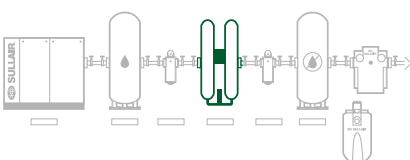

ADVANTAGES OF SULLAIR HEATED DESICCANT DRYERS

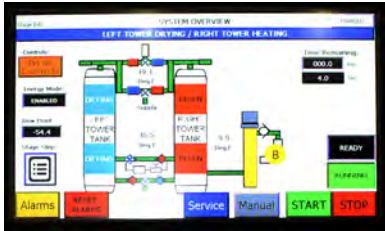

Advanced PLC Controller

A programmable PLC controller with back lit display is standard on all DHL series dryers. The controller is simple to use and comes standard with these great features:

- PLC read out
- Adjustable cycle time
- Filter change alarm
- Failure to switch contact
- Dew point monitoring contacts
- Red light alarm indicator



Optional Demand Cycle Controller — Dew Point Meter

The dew point transmitters are reliable, compact and provide continuous monitoring of the dryer performance. With available options, the monitors can be used as indicators, alarm units or controllers. Its simple but powerful interface permits the user to choose between multiple units, output data to a PC using the serial interface, set alarm levels and do field calibration of the sensor.

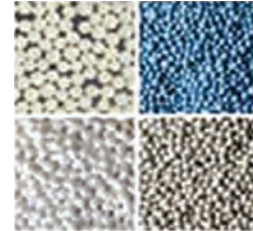

Desiccant Adsorption

Sullair uses a high quality activated alumina desiccant for all our desiccant dryers. The desiccant has high crush strength media with a very high surface/volume ratio. To achieve alternative dew points the Sullair dryer uses a mixture of adsorption media.



Butterfly Valve

These versatile valves provide precision control and bubble tight shut off. The digitally controlled actuators have easy PLC interface and feature fast response times. The butterfly valve is carbon steel with stainless steel disc and staff (800 scfm and above). The tongue-and-groove seat design ensures complete isolation of the flowing media from the body and stem. Rugged and reliable, these valves are designed to provide years of trouble free service.



High Efficiency Blower

The centrifugal blower is sized optimally to provide continuous air stream to the heater for regeneration.

The blower is equipped with:

- Intake filter
- Muffler for quieter operation
- Safety belt guard and check
- Relief valves for high-pressure safety



Angle Body Piston Valve

The high performance two-way direct acting valves are designed for reliability and durability. The valve uses a profiled disc in conjunction with a high-resolution compact positioned and linear feedback potentiometer to provide precise proportional flow. The stainless steel internals and a tough fiber composite actuator body, along with the use of oversized bearing and Viton seals makes it possible to consistently provide smooth piston movement for an extended time period.

COMPRESSED AIR FILTRATION AND MIST ELIMINATORS



Sullair Family of Filtration

- Superior filtration from 1 micron to .01 micron
- Durable element construction
- Efficient drain layer ensures continued performance after optimal element change periods

Particulate Filters: F and FR Elements

- High efficiency filters remove particles to 1 micron, including coalesced liquid water and lubricants
- Maximum remaining aerosol content after filtration is 0.5 ppm at 70°F (21°C)

High Efficiency Coalescing Filtration: H and HR Elements

- Maximum filtration to remove particulate down to 0.01 micron, including water and oil aerosols. Maximum remaining oil aerosol content of 0.01 ppm at 70°F (21°C), when used with Sullair particulate filters

Vapor Removal: C Elements

- Filters with activated carbon remove lubricant and hydrocarbon odors
- Remaining vapor content is less than 0.003 ppm (excluding methane).
- This filter installation should always be preceded by high efficiency filter grades.

High Pressure: HP Element

- Filters are available for pressures up to 725 psig (49.9 bar)

High Temperature: HT Element

- Filters are available for temperatures up to 350°F (176.6°C)

Ultra Filter: U Element

- For sensitive and high-end applications including pharmaceutical grade, Sullair offers the Ultra Filter, an absolute high efficiency particulate filter. (0.01 Micron Absolute)

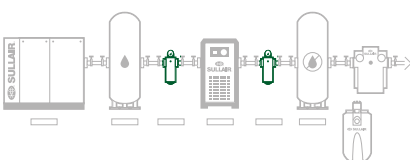

*FX = Standard NPT inlet and outlet ports
(BSP optional)*

FW = Flange inlet and outlet ports



SULLAIR COMPRESSED AIR FILTERS

Sullair Family of Filtration

Sullair filters protect your plant equipment and processes, improve your product quality and reduce your energy costs. Sullair offers filtration products in an application range from general purpose air to the most stringent food and pharmaceutical applications. Sullair filters are available from 25 to 17,700 scfm, 15 to 725 psig, and 36°F (2°C) to 350°F (177°C).

- Filtration equipment includes pre-filters, high efficiency filters, high-pressure high-temperature and odor-removal filters.
- The type, number, and placement of filters depend on the applications and the degree of contaminant removal required.
- Certifications: ISO 8573-1, ASME, CRN

Element Features

- 7 element types
- Superior construction
- Efficient drainage layer
- Hydrophobic micro fiber
- Deep pleats
- Stainless steel cores
- Special disruptive pattern
- PVC impregnated layer
- End cap key fit

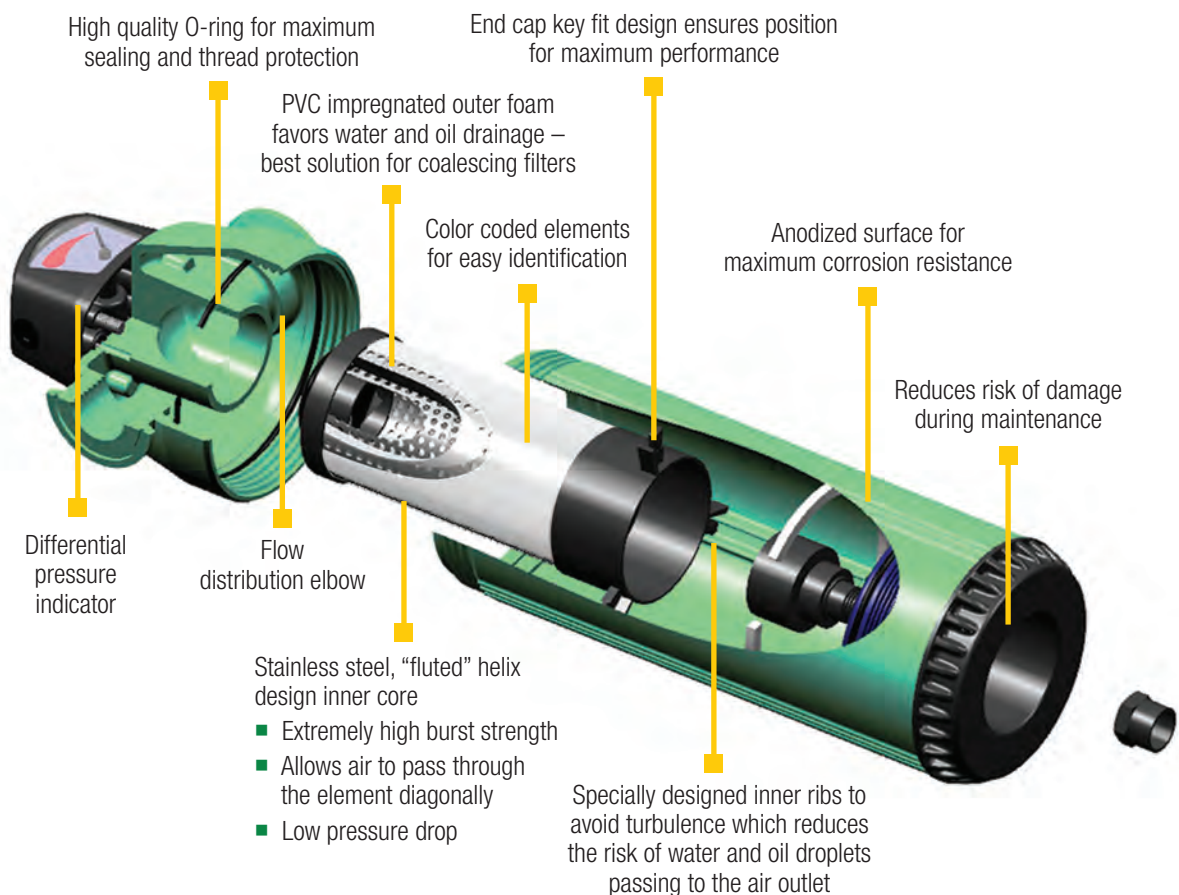

STATE OF THE ART FILTER ELEMENT AND FEATURES



The Sullair range of compressed air filters has been designed from the outset to meet current and forthcoming requirements for compressed air quality. Using aerospace technology, Sullair has optimized the flow path through the housing and element, significantly reducing air turbulence and pressure losses. Providing an optimal flow path is key to reducing pressure drop and system operating costs.



Drainage Ribs

Filter housing and element integrate to provide capillary action which greatly improves liquid drainage. Interaction between housing and element also ensures maximum coalescing performance is achieved at all times.



Recessed Drain

Specially designed auto drain system protects the auto drain against damage during shipping, handling and installation.

THE FILTRATION PROCESS

Deep Bed Pleating

For particle and aerosol removal, deep bed pleating provides 450% more filter media than an ordinary element, giving a larger filtration area, lower flow velocities, increased dirt holding capacity, lower running costs and a more compact filter element. Graded density further improves filter life and overall performance.

Oil Vapor Removal

While mechanical filtration is capable of removing extremely fine liquids and solid particles, it cannot remove gaseous contaminants such as oil vapor or odors. To efficiently remove these vapors, Sullair FXC and FWC filters employ adsorption techniques.



Micro-glass filter media

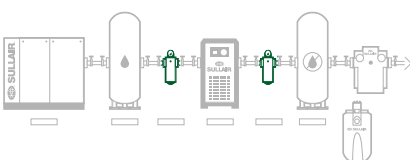

SULLAIR MIST ELIMINATORS



The time-tested range of Sullair Mist Eliminators combine extensive research and development with decades of experience in compressed air treatment.

Sullair now offers the ideal solution to ever increasing demands from the industry for clean, high quality compressed air, efficient removal of oil-mist carryover from piston or oil flooded rotary compressors.

Compressed air processing equipment must have a very low pressure drop, long service life, and be strong enough to withstand the most harsh operating conditions. Protection from slugs of oil or compressor air/oil separator failure is essential.

The range of Mist Eliminators is specifically designed to meet these demands and will optimize oil removal while ensuring extremely low pressure drop and long service life.

Element

- Ultra low .05 psi differential
- High load factor compared to conventional hand packed media which is prone to poor performance under varying load conditions
 - Provides 9–10 times greater filtration surface area, greater dirt holding capability and lower pressure drop
 - Eliminates migration of airflow to area of least resistance, also known as “channeling”
 - Eliminates the shedding of media
 - Consistent quality
- Strong stainless steel support sleeve construction
 - Eliminates rust and corrosion which can contaminate the air system
 - Integral support of the filtration media to eliminate bypass of contaminants
- For the removal of particles down to 1 micron including coalesced liquid water and oil providing a maximum remaining oil aerosol content of 0.5 ppm

Special machine pleated element construction

The machined pleating of the filter media increases its stability under changing loads and reduces the specific surface tension.

Low Pressure Drop and Operating Costs

The Sullair Mist Eliminator's pressure drop is one of the lowest available at 0.5 psi which is typically 4 psi lower than conventional filters. This provides significant energy savings based on the rule of thumb that for every 2 psi pressure drop that is eliminated, a 1% energy reduction in compressor horsepower is achieved.

Therefore annual energy savings would be:

4 psi = 2% savings in lost compressor power

Annual energy savings on 100 hp system

$\$0.05/\text{kWh} \times 8760 \text{ hours} \times 74.6 \text{ kW} \times 2\% = \$ 653$

$\$0.08/\text{kWh} \times 8760 \text{ hours} \times 74.6 \text{ kW} \times 2\% = \1046

$\$0.10/\text{kWh} \times 8760 \text{ hours} \times 74.6 \text{ kW} \times 2\% = \1307

SP OIL/WATER SEPARATORS



FEATURES AND BENEFITS

- Less than 10 ppm guarantee
- Rugged HDPE construction
- Easy installation
- Place it and forget it
- Maintenance free
- No pumps, sensors, or pre-separation filter pads
- No messy element changes
- No power consumption
- No fumes
- No odors
- Disposal as non-hazardous special waste
- Environmentally considerate

SP's are proven to handle condensate containing these common compressor lubricants (including emulsified and silicone condensate solutions):

- Polyglycols
- Diester-based lubricants
- PAO-based lubricants
- Glycol-based lubricants
- Silicon-based fluids (++)
- Hydraulic lubricants
- Food grade lubricant
- Mineral-based lubricants

++ Silicone Pak required

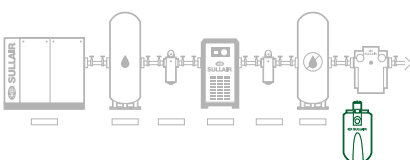

THE PERFORMANCE OF SULLAIR SP OIL/WATER SEPARATORS



The Problem

Compressed air systems generate liquid condensate that is a combination of water, oil and various other contaminants. Failure to remove these contaminants is bad for the environment and risks substantial regulatory penalties and costly remediation.

For example: A 1000 cfm (1700 m³/hr) compressor with a refrigerated dryer can produce over 57,000 gallons of condensate per year. One gallon of oil can cover 4 acres of water surface. This oil:

- Inhibits the operation of water treatment plants by choking bacteria used for sewage digestion
- Kills plants, fish and animals by reducing oxygen in water

The Green Solution

SP model Oil/Water Separators are engineered molecular filtration solutions for condensate discharge problems. These units are designed for molecular filtration of condensate, including emulsified lubricant solutions. SP units have a Performance Guarantee of less than 10 ppm oil carryover.

SP model Oil/Water Separators are engineered to minimize maintenance and reduce the cost of dealing with wastewater streams. This advanced molecular filtration system removes all types of lubricants, providing a truly scientific solution to the condensate problem.

SP units are filled with a media bed formulated to attract and hold contaminants, while at the same time repelling water molecules. Wastewater passes through the media bed and traps the contaminants. The lubricants are actually bonded to the media bed, virtually eliminating the possibility of ground water contamination from the spent bed.

Unlike gravity-type oil/water separators that use elements and time to pre-filter condensate, the SP units need no pumps, sensors or pre-separation filter pads. In addition, the rugged internal piping and a fail-safe decompression chamber assure proper operation.

All SP Oil/Water Separators contain media of the highest quality substrate. The media is a product of a proprietary sequenced process that applies the proper layers under tight quality assurance standards.

In most cases, used SP unit disposal can be managed by a regular waste management pick up service, provided the proper paperwork is completed.

DRAINS



FEATURES AND BENEFITS

The Ultra — Zero Air Loss Drain

- Zero air loss during the discharge cycle
- Compressed air systems up to 3600 scfm (101.9 m³/min)
- Simple to install, easy to maintain
- Many programmable features
- Integrated mesh strainer
- Valve is fully serviceable
- Anti-air lock

The Mini — Zero Air Loss Drain

- No electricity required
- Zero air loss during the discharge cycle
- Designed for any size downstream filters
- Simple to install, easy to maintain
- Valve is fully serviceable

Timed Solenoid Drain

- Does not air lock during operation
- Works with any size system
- Dual thread inlet
- Valve is fully serviceable
- Mounting can be vertical or horizontal
- Built-in test feature
- UL/CUL approved

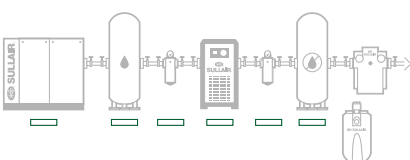

SULLAIR DRAIN FAMILY



The Ultra – Zero Air Loss Drain

The Ultra is designed to remove condensate from compressors and dryers up to 3600 scfm capacity. The operation is automatic and there is zero air lost during the condensate discharge cycle.

The Ultra also offers many programmable features to allow it to be customized to the application. Alarm contacts can be programmed N.O. or N.C. Service alarm interval can be set, anti-air lock feature can be set, as well as many other features. It also offers an array of fault alarms should the drain stop functioning correctly.



The Mini – Zero Air Loss Drain

The Mini is designed to remove condensate from air filters up to any size and type. It utilizes internal magnets for its power source requiring no electrical power. The operation is automatic and there is zero air lost during the condensate discharge cycle.



Timed Solenoid Drain

The Timed Solenoid is designed to remove condensate from any compressed air application. Its unique design includes a built-in shut off valve and strainer. The strainer protects the valve and orifice from becoming plugged with debris and the shut off valve allows for safe isolation from the air source when maintenance is performed.

ABOUT SULLAIR

For more than 50 years, Sullair has been on the leading edge of compressed air solutions. We were one of the first to execute rotary screw technology in our air compressors. And our machines are famous all over the world for their legendary durability. As the industry moves forward, Sullair will always be at the forefront with quality people, innovative solutions, and air compressors that are built to last.

Sullair was founded in Michigan City, Indiana in 1965, and has since expanded with a broad international network to serve customers in every corner of the globe. Sullair has offices in Chicago and manufacturing facilities in the United States, China and India — all ISO 9001 certified to assure the highest quality standards in manufacturing.

We have centered our operations around three key pillars: innovation, durability and people.

INNOVATION

Sullair has a long history of breakthrough solutions, from cutting-edge rotary screw technology in our air compressors to premium lubricants including the 10,000-hour Sullube®. We continuously explore new ideas and technologies to find better, more energy efficient compressed air solutions. Our customers recognize this innovative history and look for more to come.

DURABILITY

Our customers describe Sullair air compressors as bulletproof — and the proof can be viewed on roadsides. Do you ever see well-used Sullair compressors on construction sites? That's because they are still running! We have profiled a number of our customers including a factory owner in Rockford, Illinois, who has used the same Sullair compressor since 1979, and we know there are others out there operating even older units.

PEOPLE

At the end of the day, the people are what tie all of this together. We are proud to say that Sullair employees, our experienced distributors and our loyal customers are Always There.

REFRIGERATED COMPRESSED AIR DRYERS



RN NON-CYCLING MODELS

60HZ MOTOR FREQUENCY MODEL	ELECTRICAL	AC / WC	CAPACITY		INLET-OUTLET CONNECTION	DRAIN	WIDTH		DEPTH		HEIGHT		WEIGHT	
			scfm	m ³ /min			in	mm	in	mm	in	mm	lbs	kg
RN-5	115-1-60	AC	5	0.14	1/2" NPT	3/8"	14	355	14	355	24	609	85	38
RN-10	115-1-60	AC	10	0.28	1/2" NPT	3/8"	14	355	14	355	24	609	85	38
RN-15	115-1-60	AC	15	0.42	1/2" NPT	3/8"	14	355	14	355	24	609	85	38
RN-25	115-1-60	AC	25	0.7	1/2" NPT	3/8"	16	406	14	355	24	609	95	43
RN-25	230-1-60	AC	25	0.7	1/2" NPT	3/8"	16	406	14	355	24	609	95	43
RN-35	115-1-60	AC	35	0.99	1/2" NPT	3/8"	16	406	18	457	24	609	109	49
RN-35	230-1-60	AC	35	0.99	1/2" NPT	3/8"	16	406	18	457	24	609	109	49
RN-50	115-1-60	AC	50	1.4	3/4" NPT	3/8"	16	406	18	457	24	609	109	49
RN-50	230-1-60	AC	50	1.4	3/4" NPT	3/8"	16	406	18	457	24	609	109	49
RN-75	115-1-60	AC	75	2.1	3/4" NPT	3/8"	16	406	18	457	29	736	143	65
RN-75	230-1-60	AC	75	2.1	3/4" NPT	3/8"	16	406	18	457	29	736	143	65
RN-100	115-1-60	AC	100	2.8	3/4" NPT	3/8"	16	406	18	457	29	736	165	75
RN-100	230-1-60	AC	100	2.8	3/4" NPT	3/8"	16	406	18	457	29	736	165	75
RN-125	115-1-60	AC	125	3.5	1-1/2" NPT	3/8"	18	457	22	546	32	813	197	89
RN-125	230-1-60	AC	125	3.5	1-1/2" NPT	3/8"	18	457	22	546	32	813	197	89
RN-150	115-1-60	AC	150	4.2	1-1/2" NPT	3/8"	18	457	24	609	32	813	215	97
RN-150	230-1-60	AC	150	4.2	1-1/2" NPT	3/8"	18	457	24	609	32	813	215	97
RN-175	230-1-60	AC	175	4.9	1-1/2" NPT	3/8"	22	546	24	609	35	889	243	110
RN-200	230-1-60	AC	200	5.6	1-1/2" NPT	3/8"	22	546	24	609	35	889	243	110
RN-250	230-1-60	AC	250	7	1-1/2" NPT	3/4"	28	559	24	609	50	1270	465	210
RN-250	230-3-60	AC	250	7	1-1/2" NPT	3/4"	28	559	24	609	50	1270	465	210
RN-250	460-3-60	AC	250	7	1-1/2" NPT	3/4"	28	559	24	609	50	1270	465	210
RN-250	575-3-60	AC	250	7	1-1/2" NPT	3/4"	28	559	24	609	50	1270	465	210
RN-325	230-3-60	AC	325	9.2	2" NPT	3/4"	28	559	24	609	50	1270	494	224
RN-325	460-3-60	AC	325	9.2	2" NPT	3/4"	28	559	24	609	50	1270	494	224
RN-325	575-3-60	AC	325	9.2	2" NPT	3/4"	28	559	24	609	50	1270	494	224

50HZ MOTOR FREQUENCY MODEL	ELECTRICAL	AC / WC	CAPACITY		INLET-OUTLET CONNECTION	DRAIN	WIDTH		DEPTH		HEIGHT		WEIGHT	
			scfm	m ³ /min			in	mm	in	mm	in	mm	lbs	kg
RN-15	220-1-50	AC	15	0.42	1/2" NPT	3/8"	13.8	351	13.8	351	24	610	71	32
RN-25	220-1-50	AC	25	0.7	1/2" NPT	3/8"	15.5	396	13.8	351	24	610	75	34
RN-35	220-1-50	AC	35	0.99	1/2" NPT	3/8"	15.5	396	17.7	450	23.2	592	95	43
RN-50	220-1-50	AC	50	1.4	3/4" NPT	3/8"	15.5	396	17.7	450	23.2	592	95	43
RN-75	220-1-50	AC	75	2.1	3/4" NPT	3/8"	15.5	396	17.5	445	28.7	729	125	57
RN-125	220-1-50	AC	125	3.5	1-1/2" NPT	3/8"	17.5	445	21.4	546	31.6	805	176	80
RN-175	220-1-50	AC	175	4.9	1-1/2" NPT	3/8"	21.4	546	23.3	594	34.2	871	218	99
RN-200	220-1-50	AC	200	5.6	1-1/2" NPT	3/8"	21.4	546	23.3	594	34.2	871	218	99
RN-250	220-1-50	AC	250	7	1-1/2" NPT	3/4"	27.9	711	23.3	594	49.8	1265	309	140
RN-325	220-1-50	AC	325	9.2	2" NPT	3/4"	27.9	711	23.3	594	49.8	1265	309	140

CORRECTION FACTOR FOR MODELS RN AND RD

INLET PRESSURE										
psig	50	60	75	100	115	125	150	175	200	
bar	3.5	4.1	5	7	7.9	8.5	10	12	14	
Factor Pressure: F1*	0.75	0.77	0.85	1	1.06	1.1	1.16	1.25	1.3	

INLET TEMPERATURE										
°F	85	90	95	100	110	120	130	140	150	
°C	29	32	35	38	43	49	54	60	65	
Factor Inlet: F2*	1.2	1.14	1.08	1	0.75	0.6	0.5	0.45	0.35	

* Flow Correction Factors | Capacity correction to be used when operating conditions differ from those shown above. To obtain dryer capacity at new conditions, multiply nominal capacity x F1 x F2 x F3.

AMBIENT TEMPERATURE										
°F	60	80	90	100	105	110	115	120	200	
°C	16	26	32	38	40	43	46	49	14	
Factor Ambient: F3*	1.12	1.08	1.06	1	0.96	0.9	0.8	0.65	1.3	

PERFORMANCE DATA BASED ON:		
Ambient temperature	100°F	25°C
Inlet temperature	100°F	35°C
Inlet pressure	100 psig	7 bar

For flow rates at other conditions, please contact Sullair for correct sizing.

Performance data obtained and presented in accordance with CAGI Standard No. ADF 100, "Refrigerated Compressed Air Dryers - Methods for Testing and Rating."

REFRIGERATED COMPRESSED AIR DRYERS



RD DIGITAL CYCLING MODELS

60HZ MOTOR FREQUENCY MODEL	ELECTRICAL	AC / WC	CAPACITY		INLET-OUTLET CONNECTION	DRAIN	WIDTH		DEPTH		HEIGHT		WEIGHT	
			scfm	m ³ /min			in	mm	in	mm	in	mm	lbs	kg
RD-400	230-3-60	AC	400	11.3	2" NPT	3/4"	28	711	23	589	50	1265	525	238
RD-400	460-3-60	AC	400	11.3	2" NPT	3/4"	28	711	23	589	50	1265	525	238
RD-400	575-3-60	AC	400	11.3	2" NPT	3/4"	28	711	23	589	50	1265	525	238
RD-500	230-3-60	AC	500	14.1	2" NPT	3/4"	59	1500	32	810	46	1166	807	366
RD-500	460-3-60	AC	500	14.1	2" NPT	3/4"	59	1500	32	810	46	1166	807	366
RD-500	575-3-60	AC	500	14.1	2" NPT	3/4"	59	1500	32	810	46	1166	807	366
RD-700	230-3-60	AC / WC	700	19.8	3" NPT	3/4"	59	1500	32	810	46	1166	900	408
RD-700	460-3-60	AC / WC	700	19.8	3" NPT	3/4"	59	1500	32	810	46	1166	900	408
RD-700	575-3-60	AC / WC	700	19.8	3" NPT	3/4"	59	1500	32	810	46	1166	900	408
RD-850	230-3-60	AC / WC	850	24	3" NPT	3/4"	46	1165	32	810	59	1500	952	431
RD-850	460-3-60	AC / WC	850	24	3" NPT	3/4"	46	1165	32	810	59	1500	952	431
RD-850	575-3-60	AC / WC	850	24	3" NPT	3/4"	46	1165	32	810	59	1500	952	431
RD-1000	460-3-60	AC / WC	1000	28.3	3" NPT	3/4"	46	1165	32	810	74	1885	1178	534
RD-1000	575-3-60	AC / WC	1000	28.3	3" NPT	3/4"	46	1165	32	810	74	1885	1178	534
RD-1200	460-3-60	AC / WC	1200	33.9	3" NPT	1-1/4"	46	1165	46	810	74	1885	1520	690
RD-1200	575-3-60	AC / WC	1200	33.9	3" NPT	1-1/4"	46	1165	46	1165	74	1885	1520	690
RD-1600	460-3-60	AC / WC	1600	45.3	4" FLG	1-1/4"	60	1524	46	1165	74	1885	1972	894
RD-1600	575-3-60	AC / WC	1600	45.3	4" FLG	1-1/4"	60	1524	46	1165	74	1885	1972	894
RD-2000	460-3-60	AC / WC	2000	56.6	4" FLG	1-1/4"	60	1524	46	1165	74	1885	2005	909
RD-2000	575-3-60	AC / WC	2000	56.6	4" FLG	1-1/4"	60	1524	46	1165	74	1885	2005	909
RD-2400	460-3-60	AC / WC	2400	67.9	6" FLG	1-1/4"	86	2190	46	1165	79	2000	2225	1009
RD-2400	575-3-60	AC / WC	2400	67.9	6" FLG	1-1/4"	86	2190	46	1165	79	2000	2225	1009
RD-3000	460-3-60	AC / WC	3000	84.9	6" FLG	1-1/4"	86	2190	46	1165	79	2000	2456	1114
RD-3000	575-3-60	AC / WC	3000	84.9	6" FLG	1-1/4"	86	2190	46	1165	79	2000	2456	1114
RD-3800	460-3-60	AC / WC	3800	107.6	6" FLG	1-1/4"	109	2760	47	1016	79	2000	2759	1251
RD-3800	575-3-60	AC / WC	3800	107.6	6" FLG	1-1/4"	109	2760	47	1016	79	2000	2759	1251
RD-5000	460-3-60	AC / WC	5000	141.6	8" FLG	1-1/4"	100	2540	66	1676	79	2000	2820	1279
RD-5000	575-3-60	AC / WC	5000	141.6	8" FLG	1-1/4"	100	2540	66	1676	79	2000	2820	1279
RD-6000	460-3-60	AC / WC	6000	169.9	8" FLG	1-1/4"	100	2540	66	1676	85	2159	3150	1428
RD-6000	575-3-60	AC / WC	6000	169.9	8" FLG	1-1/4"	100	2540	66	1676	85	2159	3150	1428

50HZ MOTOR FREQUENCY MODEL	ELECTRICAL	AC / WC	CAPACITY		INLET-OUTLET CONNECTION	DRAIN	WIDTH		DEPTH		HEIGHT		WEIGHT	
			scfm	m ³ /min			in	mm	in	mm	in	mm	lbs	kg
RD-400	400-3-50	AC	400	11.3	2" NPT	3/4"	28	711	23	589	50	1265	341	155
RD-500	400-3-50	AC	500	14.1	2" NPT	3/4"	59	1496	32	810	46	1166	1058	480
RD-700	400-3-50	AC / WC	700	19.8	3" NPT	3/4"	59	1496	32	810	46	1166	1058	480
RD-850	400-3-50	AC / WC	850	24	3" NPT	3/4"	46	1165	32	810	59	1490	1102	500
RD-1000	400-3-50	AC / WC	1000	28.3	3" NPT	3/4"	46	1165	32	810	74	1885	1124	510
RD-1200	400-3-50	AC / WC	1200	33.9	3" NPT	1-1/4"	46	1165	45	1155	74	1885	1124	510
RD-1600	400-3-50	AC / WC	1600	45.3	4" FLG	1-1/4"	59	1500	46	1165	75	1900	1675	760
RD-2000	400-3-50	AC / WC	2000	56.6	4" FLG	1-1/4"	59	1500	46	1165	75	1900	1708	775
RD-2400	400-3-50	AC / WC	2400	67.9	6" FLG	1-1/4"	86	2190	46	1165	79	2000	1929	875
RD-3000	400-3-50	AC / WC	3000	84.9	6" FLG	1-1/4"	86	2190	46	1165	79	2000	2160	980
RD-3800	400-3-50	AC / WC	3800	107.6	6" FLG	1-1/4"	109	2760	39	1000	79	2000	2414	1095
RD-5000	400-3-50	AC / WC	5000	141.6	8" FLG	1-1/4"	91	2310	65	1660	79	2000	2425	1100
RD-6000	400-3-50	AC / WC	6000	169.9	8" FLG	1-1/4"	91	2310	65	1660	84	2140	2755	1250



REFRIGERATED COMPRESSED AIR DRYERS



RC CYCLING MODELS

60HZ MOTOR FREQUENCY MODEL	ELECTRICAL	AC / WC	CAPACITY		INLET-OUTLET CONNECTION	DRAIN	WIDTH		DEPTH		HEIGHT		WEIGHT	
			scfm	m ³ /min			in	mm	in	mm	in	mm	lbs	kg
RC-150	115-1-60	AC	150	4.2	1-1/2" NPT	3/8"	23	589	28	711	48	1214	451	204
RC-150	230-1-60	AC	150	4.2	1-1/2" NPT	3/8"	23	589	28	711	48	1214	451	204
RC-175	230-1-60	AC	175	4.9	1-1/2" NPT	3/8"	23	589	28	711	48	1214	495	224
RC-200	230-1-60	AC	200	5.6	1-1/2" NPT	3/8"	23	589	28	711	48	1214	515	234
RC-250	230-3-60	AC	250	7	1-1/2" NPT	3/4"	34	863	30	764	50	1270	600	272
RC-250	460-3-60	AC	250	7	1-1/2" NPT	3/4"	34	863	30	764	50	1270	600	272
RC-250	575-3-60	AC	250	7	1-1/2" NPT	3/4"	34	863	30	764	50	1270	600	272
RC-325	230-3-60	AC	325	9.2	2" NPT	3/4"	34	863	30	764	50	1270	690	312
RC-325	460-3-60	AC	325	9.2	2" NPT	3/4"	34	863	30	764	50	1270	690	312
RC-325	575-3-60	AC	325	9.2	2" NPT	3/4"	34	863	30	764	50	1270	690	312
RC-400	230-3-60	AC	400	11.3	2" NPT	3/4"	34	863	30	764	50	1270	752	341
RC-400	460-3-60	AC	400	11.3	2" NPT	3/4"	34	863	30	764	50	1270	752	341
RC-400	575-3-60	AC	400	11.3	2" NPT	3/4"	34	863	30	764	50	1270	752	341
RC-500	230-3-60	AC	500	14.1	2" NPT	3/4"	46	1166	32	810	59	1491	1000	453
RC-500	460-3-60	AC	500	14.1	2" NPT	3/4"	46	1166	32	810	59	1491	1000	453
RC-500	575-3-60	AC	500	14.1	2" NPT	3/4"	46	1166	32	810	59	1491	1000	453
RC-700	230-3-60	AC / WC	700	19.8	3" NPT	3/4"	46	1166	32	810	59	1491	847	384
RC-700	460-3-60	AC / WC	700	19.8	3" NPT	3/4"	46	1166	32	810	59	1491	847	384
RC-700	575-3-60	AC / WC	700	19.8	3" NPT	3/4"	46	1166	32	810	59	1491	847	384
RC-850	230-3-60	AC / WC	850	24	3" NPT	3/4"	46	1166	32	810	59	1491	952	432
RC-850	460-3-60	AC / WC	850	24	3" NPT	3/4"	46	1166	32	810	59	1491	952	432
RC-850	575-3-60	AC / WC	850	24	3" NPT	3/4"	46	1166	32	810	59	1491	952	432
RC-1000	230-3-60	AC / WC	1000	28.3	3" NPT	3/4"	46	1166	32	810	75	1900	1544	700
RC-1000	460-3-60	AC / WC	1000	28.3	3" NPT	3/4"	46	1166	32	810	75	1900	1544	700
RC-1000	575-3-60	AC / WC	1000	28.3	3" NPT	3/4"	46	1166	32	810	75	1900	1544	700
RC-1200	460-3-60	AC / WC	1200	33.9	3" NPT	1-1/4"	46	1166	46	1166	75	1900	1600	726
RC-1200	575-3-60	AC / WC	1200	33.9	3" NPT	1-1/4"	46	1166	46	1166	75	1900	1600	726
RC-1600	460-3-60	AC / WC	1600	45.3	4" FLG	1-1/4"	59	1499	46	1166	75	1900	2246	1019
RC-1600	575-3-60	AC / WC	1600	45.3	4" FLG	1-1/4"	59	1499	46	1166	75	1900	2246	1019
RC-2000	460-3-60	AC / WC	2000	56.6	4" FLG	1-1/4"	59	1499	46	1166	75	1900	2306	1046
RC-2000	575-3-60	AC / WC	2000	56.6	4" FLG	1-1/4"	59	1499	46	1166	75	1900	2306	1046
RC-2400	460-3-60	AC / WC	2400	67.9	6" FLG	1-1/4"	86	2184	46	1166	79	2006	2580	1170
RC-2400	575-3-60	AC / WC	2400	67.9	6" FLG	1-1/4"	86	2184	46	1166	79	2006	2580	1170
RC-3000	460-3-60	AC / WC	3000	84.9	6" FLG	1-1/4"	86	2184	46	1166	79	2006	2925	1326
RC-3000	575-3-60	AC / WC	3000	84.9	6" FLG	1-1/4"	86	2184	46	1166	79	2006	2925	1326

50HZ MOTOR FREQUENCY MODEL	ELECTRICAL	AC / WC	CAPACITY		INLET-OUTLET CONNECTION	DRAIN	WIDTH		DEPTH		HEIGHT		WEIGHT	
			scfm	m ³ /min			in	mm	in	mm	in	mm	lbs	kg
RC-150	220-1-50	AC	150	4.2	1-1/2" NPT	3/8"	23	589	28	711	48	1214	353	160
RC-175	220-1-50	AC	175	4.9	1-1/2" NPT	3/8"	23	589	28	711	48	1214	353	160
RC-200	220-1-50	AC	200	5.6	1-1/2" NPT	3/8"	23	589	28	711	48	1214	375	170
RC-250	220-1-50	AC	250	7	1-1/2" NPT	3/4"	33	846	29	744	50	1270	551	250
RC-250	400-3-50	AC	250	7	1-1/2" NPT	3/4"	33	846	29	744	50	1270	551	250
RC-325	400-3-50	AC	325	9.2	2" NPT	3/4"	33	846	29	744	50	1270	617	280
RC-400	400-3-50	AC / WC	400	11.3	2" NPT	3/4"	33	846	29	744	50	1270	650	295
RC-500	400-3-50	AC / WC	500	14.1	2" NPT	3/4"	46	1166	32	810	59	1491	1223	555
RC-700	400-3-50	AC / WC	700	19.8	3" NPT	3/4"	46	1166	32	810	59	1491	1267	575
RC-850	400-3-50	AC / WC	850	24	3" NPT	3/4"	46	1166	32	810	59	1491	1289	585
RC-1000	400-3-50	AC / WC	1000	28.3	3" NPT	3/4"	46	1166	32	810	74	1885	1433	650
RC-1200	400-3-50	AC / WC	1200	33.9	3" NPT	1-1/4"	46	1166	45	1156	74	1885	1499	680
RC-1600	400-3-50	AC / WC	1600	45.3	4" FLG	1-1/4"	59	1501	46	1166	75	1900	4334	960
RC-2000	400-3-50	AC / WC	2000	56.6	4" FLG	1-1/4"	59	1501	46	1166	75	1900	4334	960
RC-2400	400-3-50	AC / WC	2400	67.9	6" FLG	1-1/4"	86	2189	46	1166	77	1999	2458	1115
RC-3000	400-3-50	AC / WC	3000	84.9	6" FLG	1-1/4"	86	2189	46	1166	77	1999	2821	1280

CORRECTION FACTOR FOR RC MODELS – CONTINUED

REFRIGERATED COMPRESSED AIR DRYERS



RC CYCLING MODELS CONTINUED

CORRECTION FACTOR FOR RC MODELS

INLET PRESSURE									
psig	50	60	75	100	115	125	150	175	200
bar	3.5	4.1	5	7	7.9	8.5	10	12	14
Factor Pressure: F1*	0.75	0.77	0.85	1	1.06	1.1	1.16	1.25	1.3

INLET TEMPERATURE									
*F	85	90	95	100	110	120	130	140	150
*C	29	32	35	38	43	49	54	60	65
Factor Inlet: F2*	1.2	1.14	1.08	1	0.75	0.6	0.5	0.45	0.35

AMBIENT TEMPERATURE								
*F	60	80	90	100	105	110	115	120
*C	16	26	32	38	40	43	46	49
Factor Ambient: F3*	1.12	1.08	1.06	1	0.96	0.9	0.8	0.65

* **Flow Correction Factors** | Capacity correction to be used when operating conditions differ from those shown above. To obtain dryer capacity at new conditions, multiply nominal capacity x F1 x F2 x F3.

RH HIGH TEMPERATURE MODELS

60HZ MOTOR FREQUENCY MODEL	ELECTRICAL	AC / WC	CAPACITY		INLET-OUTLET CONNECTION	DRAIN	WIDTH		DEPTH		HEIGHT		WEIGHT	
			scfm	m ³ /min			in	mm	in	mm	in	mm	lbs	kg
RH-15	115-1-60	AC	15	0.42	1/2" NPT	3/8"	18	457	18	457	38	965	159	72
RH-25	115-1-60	AC	25	0.7	1/2" NPT	3/8"	18	457	18	457	38	965	159	72
RH-35	115-1-60	AC	35	0.99	1/2" NPT	3/8"	18	457	18	457	38	965	161	73
RH-50	115-1-60	AC	50	1.4	1/2" NPT	3/8"	18	457	18	457	38	965	163	74
RH-75	115-1-60	AC	75	2.1	3/4" NPT	3/8"	25	635	20	508	36	914	217	94
RH-100	115-1-60	AC	100	2.8	3/4" NPT	3/8"	25	635	20	508	36	914	238	108

CORRECTION FACTOR FOR RH MODELS

INLET PRESSURE											
psig	60	75	90	100	115	125	145	160	175	190	200
bar	4.1	5	6	7	7.9	8.5	10	11	12	13	14
Factor Pressure: F1*	0.7	0.75	0.8	0.83	0.86	0.9	0.93	0.96	1	1.1	1.12

INLET TEMPERATURE							
*F	90	100	150	180	200	210	220
*C	32	38	65	82	93	98	104
Factor Inlet: F2*	1.3	1.27	1.06	1	0.85	0.78	0.75

AMBIENT TEMPERATURE								
*F	75	85	95	100	105	115	120	120
*C	24	29	35	38	40	46	49	49
Factor Ambient: F3*	1.1	1.07	1.03	1	0.96	0.82	0.55	0.65

DEW POINT						
*F	38	41	45	50	55	60
*C	3.3	5	7.2	10	12.8	15.5
Factor Dew Point: F4*	0.65	0.73	0.8	1	1.1	1.22

* **Flow Correction Factors** | Capacity correction to be used when operating conditions differ from those shown above. To obtain dryer capacity at new conditions, multiply nominal capacity x F1 x F2 x F3.



DESICCANT REGENERATIVE DRYERS

SULLAIR HEATLESS DESICCANT MODULAR DRYERS (DMD)

Standard Features

- Completely automatic
- Compact design
- -40°F pressure dew point
- Adjustable wall mounted
- Quick and easy connection
- Long lasting high quality components

Options

- Pre- and after-filter (shipped loose)
- Mounted filters with three valve bypass
- Visual Moisture Indicator
- Energy efficient Demand Cycle Control with dew point monitor
- Dew point monitor
- -4°F or -100°F pressure dew point



Desiccant Modular Dryer

DMD drawing description:

- 1 Inlet valve
- 2 Purge exhaust valve
- 3 Pilot valve
- 4 Outlet check valve
- 5 Pressure relief valve
- 6 Purge adjustment valve
- 7 Stainless steel inlet defuser
- 8 Purge exhaust muffler
- 9 Pressure gauge
- 10 Control air line

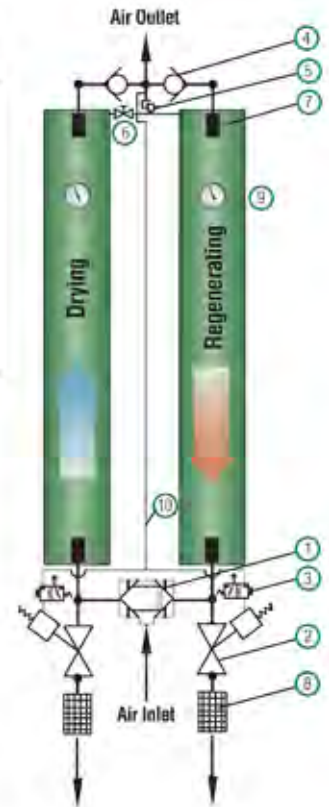

DESICCANT MODULAR DRYER

MODEL	SCFM	INLET – OUTLET CONNECTION	WIDTH IN	DEPTH IN	HEIGHT IN	WEIGHT LBS	ELECTRICAL	PRE-FILTER	AFTER-FILTER
DMD-3	3	1/2" NPT	13	10	22	32	115 - 230 / 1 / 50 & 60 Hz	FXH-25	FXFR-25
DMD-5	5	1/2" NPT	13	10	25	36	115 - 230 / 1 / 50 & 60 Hz	FXH-25	FXFR-25
DMD-10	10	1/2" NPT	13	10	36	52	115 - 230 / 1 / 50 & 60 Hz	FXH-25	FXFR-25
DMD-15	15	1/2" NPT	15	10	32	57	115 - 230 / 1 / 50 & 60 Hz	FXH-25	FXFR-25
DMD-20	20	1/2" NPT	15	10	44	79	115 - 230 / 1 / 50 & 60 Hz	FXH-25	FXFR-25
DMD-25	25	1/2" NPT	15	10	50	90	115 - 230 / 1 / 50 & 60 Hz	FXH-25	FXFR-25
DMD-30	30	1/2" NPT	15	10	59	107	115 - 230 / 1 / 50 & 60 Hz	FXH-45	FXFR-45
DMD-40	40	1-1/2" NPT	16	17	49	156	115 - 230 / 1 / 50 & 60 Hz	FXH-45	FXFR-45
DMD-50	50	1-1/2" NPT	16	17	55	172	115 - 230 / 1 / 50 & 60 Hz	FXH-65	FXFR-65
DMD-60	60	1-1/2" NPT	16	17	69	202	115 - 230 / 1 / 50 & 60 Hz	FXH-65	FXFR-65
DMD-75	75	1-1/2" NPT	16	23	51	257	115 - 230 / 1 / 50 & 60 Hz	FXH-130	FXFR-130
DMD-100	100	1-1/2" NPT	16	23	57	286	115 - 230 / 1 / 50 & 60 Hz	FXH-130	FXFR-130
DMD-120	120	1-1/2" NPT	16	23	69	334	115 - 230 / 1 / 50 & 60 Hz	FXH-130	FXFR-130
DMD-180	180	1-1/2" NPT	16	28	59	407	115 - 230 / 1 / 50 & 60 Hz	FXH-240	FXFR-240
DMD-240	240	1-1/2" NPT	16	33	59	519	115 - 230 / 1 / 50 & 60 Hz	FXH-240	FXFR-240

DESICCANT REGENERATIVE DRYERS



DESICCANT HEATLESS DRYER

MODEL	SCFM	INLET – OUTLET CONNECTION	WIDTH IN	DEPTH IN	HEIGHT IN	WEIGHT LBS	ELECTRICAL	PRE-FILTER	AFTER-FILTER
DHL-80	80	3/4" NPT	24	31	84	450	115-1-60	FXH-130	FXFR-130
DHL-100	100	1" NPT	24	31	84	550	115-1-60	FXH-130	FXFR-130
DHL-125	125	1" NPT	24	31	84	600	115-1-60	FXH-130	FXFR-130
DHL-150	150	1" NPT	24	33	84	650	115-1-60	FXH-240	FXFR-240
DHL-200	200	1" NPT	24	33	84	880	115-1-60	FXH-240	FXFR-240
DHL-250	250	1-1/2" NPT	24	39	87	1250	115-1-60	FXH-350	FXFR-350
DHL-300	300	1-1/2" NPT	24	39	87	1350	115-1-60	FXH-350	FXFR-350
DHL-400	400	2" NPT	26	45	89	1900	115-1-60	FXH-475	FXFR-475
DHL-500	500	2" NPT	26	45	89	2200	115-1-60	FXH-700	FXFR-700
DHL-600	600	2" NPT	26	45	89	2500	115-1-60	FXH-700	FXFR-700
DHL-800	800	3" FLG	40	66	93	2800	115-1-60	FXH-1350	FXFR-1350
DHL-1000	1000	3" FLG	40	66	93	4150	115-1-60	FXH-1350	FXFR-1350
DHL-1250	1250	3" FLG	40	70	93	4400	115-1-60	FXH-1350	FXFR-1350
DHL-1500	1500	3" FLG	40	70	93	4700	115-1-60	FXH-1600	FXFR-1600
DHL-2000	2000	3" FLG	40	76	97	4900	115-1-60	FWH-2500	FXFR-2500
DHL-2500	2500	4" FLG	50	93	109	5600	115-1-60	FWH-2500	FXFR-2500
DHL-3000	3000	6" FLG	50	93	109	8100	115-1-60	FWH-3800	FXFR-3800
DHL-3500	3500	6" FLG	64	118	117	8300	115-1-60	FWH-3800	FXFR-3800
DHL-4000	4000	6" FLG	64	118	117	10500	115-1-60	FWH-5000	FXFR-5000
DHL-4500	4500	6" FLG	64	120	122	11800	115-1-60	FWH-5000	FXFR-5000
DHL-5000	5000	6" FLG	64	120	122	14500	115-1-60	FWH-5000	FXFR-5000

CAPACITY CORRECTION FACTORS (FOR ALL SULLAIR DESICCANT DRYERS)

CORRECTION FACTOR FOR INLET AIR PRESSURE (F1)

INLET PRESSURE	psig	50	60	70	80	90	100	110	120	130	140	150	175	200	225	250
	bar	3.5	4.1	4.8	5.5	6.2	6.9	7.6	8.3	9	9.7	10.3	12.1	13.8	15.5	17.3
FACTOR PRESSURE: F1		0.56	0.65	0.74	0.83	0.91	1	1.04	1.08	1.12	1.16	1.2	1.29	1.37	1.45	1.52

CORRECTION FACTOR FOR INLET AIR PRESSURE (F2)

°F	70	80	90	100	105	110	115	120
	°C	21	27	32	38	40	43	46
FACTOR: F2	1.12	1.1	1.06	1	0.93	0.86	0.8	0.75

Air flow capacity = Nominal capacity of the dryer x Factor F1 x Factor F2



a division of Accudyne Industries

DESICCANT REGENERATIVE DRYERS



DESICCANT EXTERNALLY HEATED DRYER

MODEL	SCFM	INLET – OUTLET CONNECTION	WIDTH IN	DEPTH IN	HEIGHT IN	WEIGHT LBS	ELECTRICAL	KW	PRE-FILTER	AFTER-FILTER
DEX-200	200	1" NPT	34	35	92	950	460-3-60	3	FXH-240	FXRHT-240
DEX-250	250	1-1/2" NPT	34	36	92	1100	460-3-60	3	FXH-350	FXRHT-350
DEX-300	300	1-1/2" NPT	34	36	92	1250	460-3-60	5	FXH-350	FXRHT-350
DEX-400	400	2" NPT	45	47	92	1500	460-3-60	6	FXH-475	FXRHT-475
DEX-500	500	2" NPT	45	47	92	1600	460-3-60	7	FXH-700	FXRHT-700
DEX-600	600	2" NPT	45	47	92	2100	460-3-60	9	FXH-700	FXRHT-700
DEX-800	800	3" FLG	60	80	95	2500	460-3-60	11	FXH-925	FXRHT-925
DEX-900	900	3" FLG	60	80	95	2800	460-3-60	13	FXH-925	FXRHT-925
DEX-1000	1000	3" FLG	60	80	95	4100	460-3-60	15	FXH-1350	FXRHT-1350
DEX-1250	1250	3" FLG	60	80	110	4700	460-3-60	18	FXH-1350	FWRHT-1350
DEX-1500	1500	3" FLG	60	80	110	4900	460-3-60	20	FXH-1600	FWRHT-1600
DEX-2000	2000	3" FLG	62	80	110	5300	460-3-60	25	FWH-2500	FWRHT-2500
DEX-2500	2500	4" FLG	65	82	110	6200	460-3-60	25	FWH-2500	FWRHT-2500
DEX-3000	3000	6" FLG	65	82	110	7600	460-3-60	30	FWH-3800	FWRHT-3800
DEX-3500	3500	6" FLG	70	85	120	8300	460-3-60	38	FWH-3800	FWRHT-3800

DESICCANT BLOWER PURGE DRYER

MODEL	SCFM	INLET – OUTLET CONNECTION	WIDTH IN	DEPTH IN	HEIGHT IN	WEIGHT LBS	ELECTRICAL	KW	PRE-FILTER	AFTER-FILTER
DBP-500	500	2" NPT	45	71	92	2500	460-3-60	10	FXH-700	FXRHT-700
DBP-650	650	2" NPT	45	71	92	2750	460-3-60	12	FXH-700	FXRHT-700
DBP-800	800	3" FLG	60	93	95	4100	460-3-60	18	FXH-925	FXRHT-925
DBP-1000	1000	3" FLG	60	93	95	4500	460-3-60	24	FXH-1350	FXRHT-1350
DBP-1250	1250	3" FLG	60	93	95	8200	460-3-60	30	FXH-1350	FXRHT-1350
DBP-1500	1500	3" FLG	60	93	95	8200	460-3-60	36	FXH-1600	FXRHT-1600
DBP-2000	2000	4" FLG	65	106	109	9800	460-3-60	45	FWH-2500	FWFHT-2500
DBP-2500	2500	4" FLG	75	106	120	15000	460-3-60	50	FWH-2500	FWFHT-2500
DBP-3000	3000	6" FLG	75	106	120	15000	460-3-60	55	FWH-3800	FWFHT-3800
DBP-3500	3500	6" FLG	82	150	132	19000	460-3-60	60	FWH-3800	FWFHT-3800
DBP-4000	4000	6" FLG	94	160	132	19000	460-3-60	70	FWH-5000	FWFHT-5000
DBP-5000	5000	6" FLG	94	180	140	28000	460-3-60	80	FWH-5000	FWFHT-5000
DBP-6000	6000	6" FLG	CF	CF	CF	CF	460-3-60	90	FWH-6500	FWFHT-6500
DBP-7000	7000	8" FLG	CF	CF	CF	CF	460-3-60	105	FWH-8300	FWFHT-8300
DBP-7500	7500	8" FLG	CF	CF	CF	CF	460-3-60	125	FWH-8300	FWFHT-8300
DBP-9000	9000	10" FLG	CF	CF	CF	CF	460-3-60	135	FWH-10000	FWFHT-10000
DBP-10000	10000	10" FLG	CF	CF	CF	CF	460-3-60	140	FWH-10000	FXFHT-10000

CORRECTION FACTOR FOR INLET AIR PRESSURE (F1)

INLET PRESSURE	psig	50	60	70	80	90	100	110	120	130	140	150	175	200	225	250
	bar	3.5	4.1	4.8	5.5	6.2	6.9	7.6	8.3	9	9.7	10.3	12.1	13.8	15.5	17.3
FACTOR PRESSURE: F1		0.56	0.65	0.74	0.83	0.91	1	1.04	1.08	1.12	1.16	1.2	1.29	1.37	1.45	1.52

CORRECTION FACTOR FOR INLET AIR PRESSURE (F2)

FACTOR: F2	'F	70	80	90	100	105	110	115	120
	'C	21	27	32	38	40	43	46	49
		1.12	1.1	1.06	1	0.93	0.86	0.8	0.75

Air flow capacity = Nominal capacity of the dryer x Factor F1 x Factor F2



COMPRESSED AIR FILTRATION AND MIST ELIMINATORS



SPECIFICATIONS

FILTER MODEL	INLET-OUTLET PORT SIZE	CAPACITY		DIMENSION A		DIMENSION B		DIMENSION C		WEIGHT	
		scfm	m ³ /min	in	mm	in	mm	in	mm	lbs	kg
FX-25*	3/8"	25	0.7	4	101	8	203	7	178	3	1.3
FX-25	1/2"	25	0.7	4	101	8	203	7	178	3	1.3
FX-45*	1/2"	45	1.27	4	101	10	254	9	228	3	1.3
FX-65	3/4"	65	1.84	5	127	10	254	11	279	4	1.8
FX-65	1"	65	1.84	5	127	10	254	11	279	4	1.8
FX-130*	1"	130	3.68	5	127	15	381	14	355	6	2.7
FX-240*	1-1/2"	240	6.79	5	127	19	482	17	432	7	3.2
FX-350*	1-1/2"	350	9.91	5	127	21	533	19	482	8	3.6
FX-475*	2"	475	13.45	6	152	24	609	22	559	12	5.4
FX-700	2"	700	19.82	6	152	27	686	25	635	12	5.4
FX-925*	3"	925	26.19	8	203	29	736	21	533	23	10.4
FX-1350*	3"	1350	38.23	8	203	29	736	27	686	26	11.7
FX-1600*	3"	1600	45.31	8	203	42	1067	40	1016	27	12.2

* Denotes standard inlet and outlet port sizes

FILTER MODEL	MAXIMUM OPERATING PRESSURE		MAXIMUM OPERATING TEMPERATURE		MINIMUM OPERATING TEMPERATURE		STANDARD DRAIN TYPE
	psig	bar	Fahrenheit	Celsius	Fahrenheit	Celsius	
FXF	290	20	176°F	80°C	36°F	2°C	auto
FXH	290	20	176°F	80°C	36°F	2°C	auto
FXC	290	20	176°F	80°C	36°F	2°C	manual
FXFR	290	20	176°F	80°C	36°F	2°C	manual
FXHR	290	20	176°F	80°C	36°F	2°C	manual
FXFRHT	290	20	350°F	176°C	36°F	2°C	manual

[An optional zero-loss drain is available for all Sullair filters]

PRESSURE CORRECTION FACTOR FOR STANDARD PRESSURE FILTERS

Line Pressure (psig)	25	40	50	60	75	90	100	110	125	140	150	160	175	200
Correction Factor	0.49	0.62	0.69	0.76	0.86	0.95	1	1.04	1.1	1.17	1.21	1.25	1.31	1.4
Line Pressure (barg)	1	2	3	5	7	9	11	13						
Correction Factor	0.38	0.53	0.65	0.85	1	1.13	1.25	1.36						

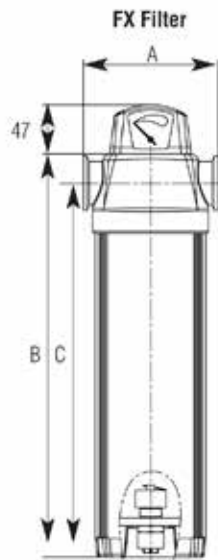

COMPRESSED AIR FILTRATION AND MIST ELIMINATORS



SPECIFICATIONS

SULLAIR ELEMENT TYPE	COLOR CODE	EFFICIENCY PERFORMANCE	MEDIA / TYPE / PATTERN	FLOW DIRECTION	DRY PRESSURE DROP		WET PRESSURE DROP	
					psig	bar	psig	bar
F	Blue	1 micron & .5 ppm carryover	Wrapped	In-to-Out	0.6	0.04	1.2	0.08
FR	Blue	Reverse 1 micron & .5 ppm carryover	Pleated	Out-to-In	0.35	0.02	0.6	0.04
FRHT	Metal	High temperature reverse 1 micron & .5 ppm carryover	Pleated	Out-to-In	0.35	0.02	0.6	0.04
H	Red	0.01 micron & .01 ppm carryover	Wrapped	In-to-Out	1.2	0.08	2.3	0.15
HR	Red	Reverse 0.01 micron & .01 ppm carryover	Pleated	Out-to-In	0.45	0.03	0.7	0.04
C	Metal	0.01 micron & .003 ppm carryover	Carbon	Out-to-In	2.3	0.15	2.3	0.15
Ultra U	White	0.01 micron absolute	Wrapped	Out-to-In	5	0.34	absolute	

FILTER MODEL	INLET-OUTLET PORT SIZE	CAPACITY		DIMENSION A		DIMENSION B		DIMENSION C		DIMENSION D		WEIGHT	
		scfm	m ³ /min	in	mm	in	mm	in	mm	in	mm	lbs	kg
FHP-60	1/4"	60	1.7	4	101	9	228	1	25	6	152	7	3.2
FHP-175	1/2"	175	4.95	4	101	9	228	1	25	6	152	7	3.2
FHP-350	3/4"	350	9.91	4	101	9	228	1	25	8	203	8	3.6
FHP-500	1"	500	14.16	5	127	5	127	1	25	10	254	14	6.3
FHP-700	1"	700	19.82	5	127	5	127	1	25	12	304	18	8.2
FHP-950	1-1/2"	950	26.9	5	127	5	127	2	50	14	355	21	9.5
FHP-1500	2"	1500	42.48	6	152	6	152	2	50	15	381	25	11
FHP-1750	2-1/2"	1750	49.56	6	152	7	177	2	50	15	381	28	13

FILTER MODEL	MAXIMUM OPERATING PRESSURE		MAXIMUM OPERATING TEMPERATURE		MINIMUM OPERATING TEMPERATURE		STANDARD DRAIN TYPE
	psig	bar	Fahrenheit	Celsius	Fahrenheit	Celsius	
FXP	725	50	176°F	80°C	36°F	2°C	manual

PRESSURE CORRECTION FACTOR FOR STANDARD PRESSURE FILTERS

Pressure psig	290	363	435	508	580	653	725
Pressure barg	20	25	30	35	40	45	50
Correction factor	0.63	0.7	0.78	0.83	0.9	0.95	1

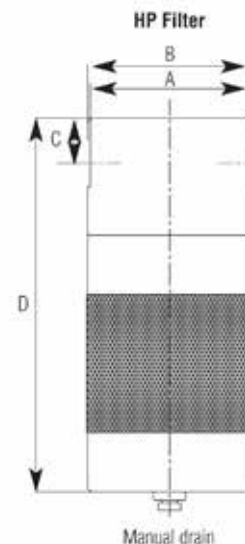

COMPRESSED AIR FILTRATION AND MIST ELIMINATORS



SPECIFICATIONS

FILTER MODEL	INLET-OUTLET PORT SIZE	DIMENSION A		DIMENSION B		DIMENSION C		DIMENSION D		MIN. CLEARANCE FOR ELEMENT CHANGE	DRAIN PORT SIZE NPT	ELEMENT QTY.
		in	mm	in	mm	in	mm	in	mm			
FW-1500	3" flange	18	457	46	1168	11	279	30	762	26"	1/2"	2
FW-1900	4" flange	18	457	46	1168	11	279	30	762	26"	1/2"	3
FW-2500	4" flange	21	533	46	1168	11	279	30	762	26"	1/2"	4
FW-3800	6" flange	23	584	50	1270	13	330	31	787	26"	1/2"	6
FW-5000	6" flange	23	584	51	1295	13	330	31	787	26"	1/2"	8
FW-6500	6" flange	29	736	53	1346	15	381	33	838	26"	1/2"	10
FW-8300	8" flange	30	762	55	1397	15	381	33	838	26"	1/2"	14
FW-10000	10" flange	32	813	58	1473	16	406	34	863	26"	1/2"	16
FW-12400	12" flange	34	864	61	1549	18	457	35	889	26"	1/2"	16

MIST ELIMINATOR MODEL	INLET-OUTLET PORT SIZE	DIMENSION A		DIMENSION B		DIMENSION C		DIMENSION D		MIN. CLEARANCE FOR ELEMENT CHANGE	DRAIN PORT SIZE NPT	SEPARATOR QTY.
		in	mm	in	mm	in	mm	in	mm			
ELM-150	2" flange	20	508	35	889	9	228	18	457	13"	1/2"	1
ELM-300	2" flange	20	508	39	990	9	228	22	558	17"	1/2"	1
ELM-600	2" flange	20	508	53	1346	9	228	36	914	31"	1/2"	1
ELM-800	3" flange	20	508	61	1549	11	279	43	1092	37"	1/2"	1
ELM-1200	3" flange	24	609	56	1422	11	279	37	939	31"	1/2"	1
ELM-1600	3" flange	24	609	62	1574	11	279	43	1092	37"	1/2"	1
ELM-2100	4" flange	28	711	56	1422	13	330	38	965	31"	1/2"	1
ELM-2750	4" flange	28	711	64	1625	13	330	44	1117	37"	1/2"	1
ELM-4200	6" flange	32	812	61	1549	15	381	39	990	31"	1/2"	1
ELM-6000	6" flange	32	812	71	1803	15	381	49	1244	41"	1/2"	1
ELM-8000	8" flange	34	863	75	1905	16	406	50	1270	41"	1/2"	1
ELM-10000	10" flange	40	1016	79	2006	19	482	51	1295	41"	1/2"	1
ELM-12000	12" flange	40	1016	101	2565	20	508	73	1854	61"	1/2"	1

FILTER MODEL	MAXIMUM OPERATING PRESSURE		MAXIMUM OPERATING TEMPERATURE		MINIMUM OPERATING TEMPERATURE		STANDARD DRAIN TYPE
	psig	bar	Fahrenheit	Celsius	Fahrenheit	Celsius	
FW/ELM	200	14	176°F	80°C	36°F	2°C	external float drain

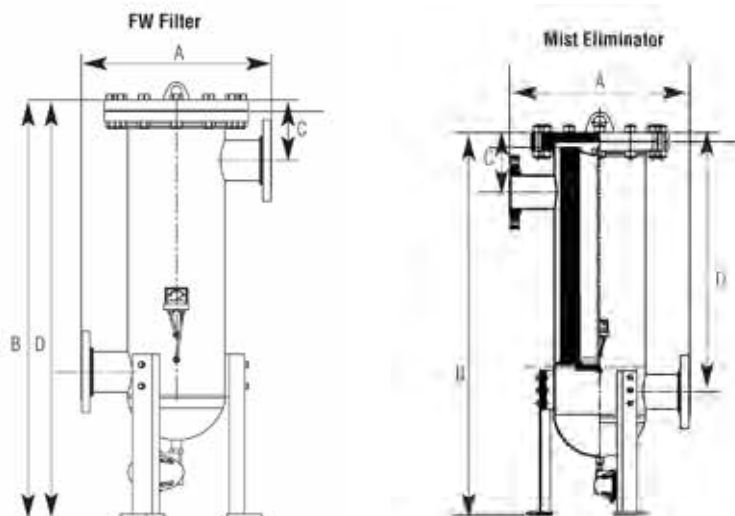

THE ULTRA SPECIFICATIONS

Voltage	115 VAC or 230 VAC
Inlet connection	1/2" NPT
Outlet connection	1/2" NPT or 3/8" hose barb
Maximum pressure	230 psi
Maximum temperature	122°F
Minimum temperature	35°F
Maximum compressor capacity	3600 cfm
Maximum drainage capacity	80 gph
Electrical protection rating	NEMA 4/IP65

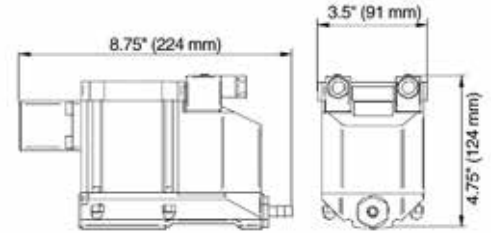

THE MINI SPECIFICATIONS

Inlet connection	1/2" NPT
Outlet connection	1/8" NPT
Maximum pressure	230 psi
Maximum temperature	122°F
Minimum temperature	35°F
Maximum filter capacity	Unlimited
Maximum drainage capacity	40 gph

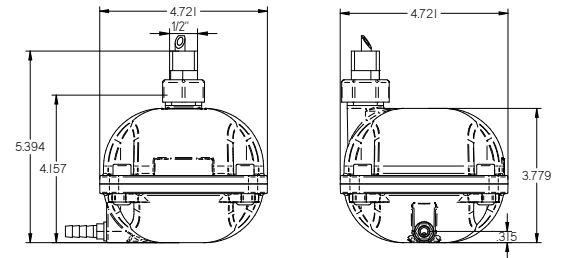

TIMED SOLENOID SPECIFICATIONS

Voltage	115 VAC or 230 VAC
Inlet connection	1/2" NPT O.D & 1/4" npt I.D.
Outlet connection	1/2" NPT
Maximum pressure	300 psi
Maximum temperature	130°F
Minimum temperature	35°F
Electrical protection rating	NEMA 4/IP65

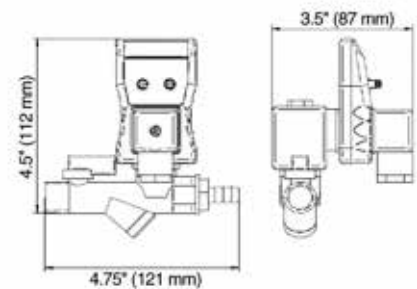



For more information, contact your local authorized Sullair distributor.